



# **BROCHURE # 58**

## **ROAD APPROACH PERMIT**

### **What is a Road Approach Permit?**

A Road Approach Permit allows you to connect private vehicular access to or from the county road system. When you apply for a Road Approach Permit, your approach will be conditioned to ensure it is constructed to Kitsap County Road Standards (as adopted under Ordinance 293-2003 Chapter 4 and KCC 11.22).

### **Why should I apply for a Road Approach?**

A Road Approach Permit is needed to access private property off of a public road as provided in RCW 36.75.130. When access driveways are constructed to County standards, it allows the road crews to properly maintain the roads, allows the roads to be plowed when it snows, and provides proper stormwater runoff.

### **How much does a Road Approach Permit Cost?**

For current fee information, see the [DCD Fees Schedule](#). Click the **Fee Schedule** link on the right hand side for the most current information.

### **What other permits may I need to construct a driveway?**

- Based on site conditions and grading quantities you may need a Site Development Activity Permit. For more information on SDAP's visit <https://www.kitsapgov.com/dcd/FormsandBrochures/SDAP.pdf>
- If the construction of the driveway includes utility work in a County right of way, you will need to apply for a permit to work on the [Right of Way](#). A bond and/or fee is required to work on the right-of way.
- If any road work other than an approach is to take place in a County right of way, then you must apply for a Use/Improve County right-of-way permit through Public Works. Visit [Right of](#)

[Way Permits \(kitsap.gov\)](#) for more information.

### **How do I obtain a Road Approach Permit?**

To begin applying for your road approach permit, please visit the [DCD Prepare, Apply, Manage](#) page for more information. When you are ready to apply, visit our [Permit Application Portal](#).

### **My Road Approach Accesses from an Unmaintained Right-Of-Way. Do I still need a permit?**

Yes. Even though the access road is unmaintained, the road approach must meet Current County Road Standards. An unmaintained road is defined as: "A road within County right of way, which is accessible to the public travel but is not maintained by the County."

In addition to a road approach permit, a Category 3 covenant is required before approval of the road approach permit per Kitsap County Ordinance 245-2000. The covenant stipulates the maintenance will be the joint responsibility of all property owners having access to the road. The covenants are to be:

- ✓ Prepared by DCD
- ✓ Signed by the owner
- ✓ Notarized
- ✓ Reviewed by DCD
- ✓ Recorded, by the property owner, at the Auditor's Office prior to the issuance of the road approach permit.

For additional information, please contact DCD Development Engineering at (360) 337-5777.



# EXAMPLE ROAD APPROACH CONSTRUCTION SPECIFICATIONS

## RETURN RADIUS

- RESIDENTIAL APPROACH - LOCAL ROAD 10'
- RESIDENTIAL APPROACH - SUB-COLLECTOR 15'
- RESIDENTIAL APPROACH - COLLECTOR 20'
- RESIDENTIAL APPROACH - MINOR ARTERIAL 25'
- RESIDENTIAL APPROACH - PRINCIPAL ARTERIAL 30'
- MAJOR APPROACH - ALL CLASSIFICATIONS 35'

## APPROACH WIDTH

- RESIDENTIAL 10'
- MAJOR 20' MIN./36' MAX.

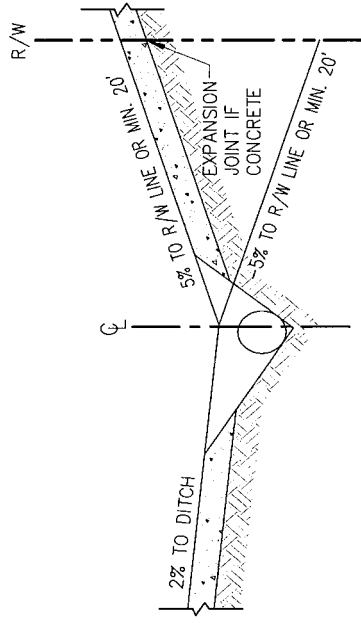
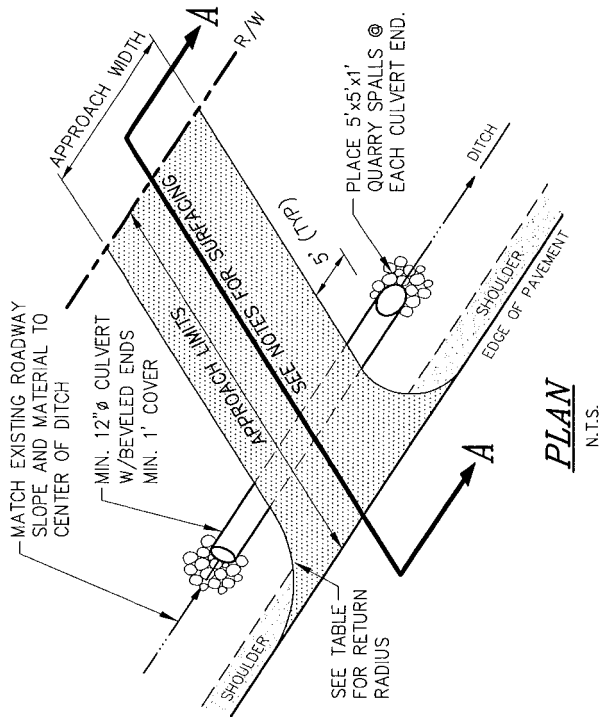

## SECTION A-A

N.T.S.

### NOTES:

1. APPROACH PAVING = MINIMUM 2" COMPACTED DEPTH HOT MIX ASPHALT, OR OVER MINIMUM 2" COMPACTED DEPTH CRUSHED SURFACING TOP COURSE, OR MINIMUM 6" REINFORCED CEMENT CONCRETE.
2. ALL PORTLAND CEMENT CONCRETE APPROACHES REQUIRE AN INSPECTION OF THE FORMS AND EXPANSION JOINT LOCATIONS PRIOR TO CONCRETE INSTALLATION.
3. APPROACH SHALL NORMALLY BE AT 90 DEGREES TO ROAD CENTERLINE, BUT CAN VARY FROM 75 TO 105 DEGREES.
4. CULVERT PIPE MUST BE CONCRETE, CMP, OR CPEP WITH QUARRY SPALLS. MINIMUM LENGTH IS 20' OR DETERMINED BY WIDTH OF APPROACH PLUS 5' EACH END (EXCLUDING BEVELED END SECTIONS).
5. IF EXISTING COUNTY ROAD SURFACE IS OTHER THAN ASPHALT CONCRETE PAVEMENT, A LIKE MATERIAL MAY BE USED ON ROAD APPROACH.

	RURAL RESIDENTIAL / MAJOR APPROACH GRAVEL SHOULDERS AND OPEN DRAINAGE	Date: 8/10/07 FIGURE 4-1
KITSAP COUNTY DEPT. OF PUBLIC WORKS 614 DIVISION STREET MS-26 PORT ORCHARD, WA 98366 TEL: (360) 337-5777 FAX: (360) 337-4857		